

WM-C-HP Drilling Template

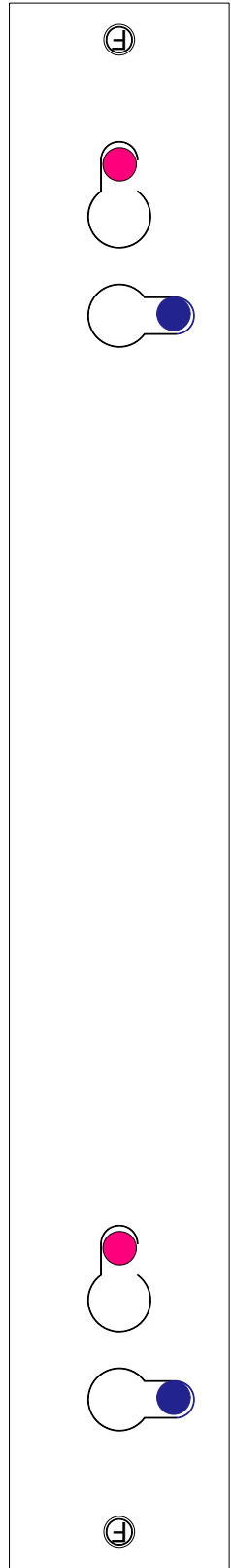

Drill for horizontal mount

Drill for vertical mount

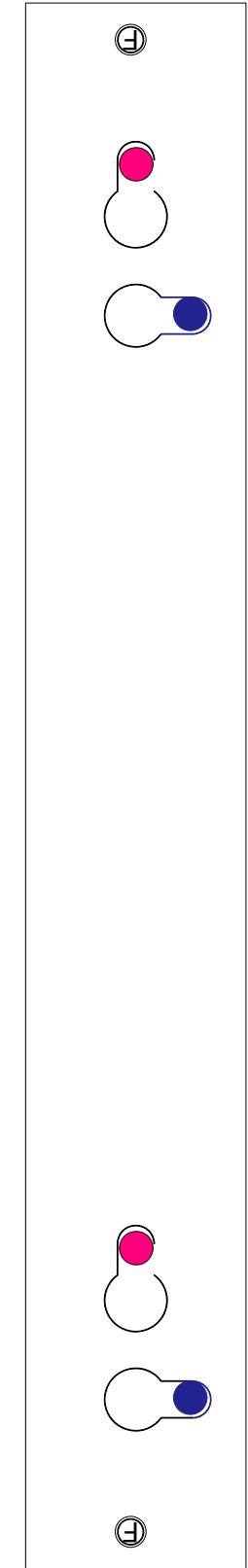

Rear of unit

Corner of unit

WM-C-HP Assembly Details

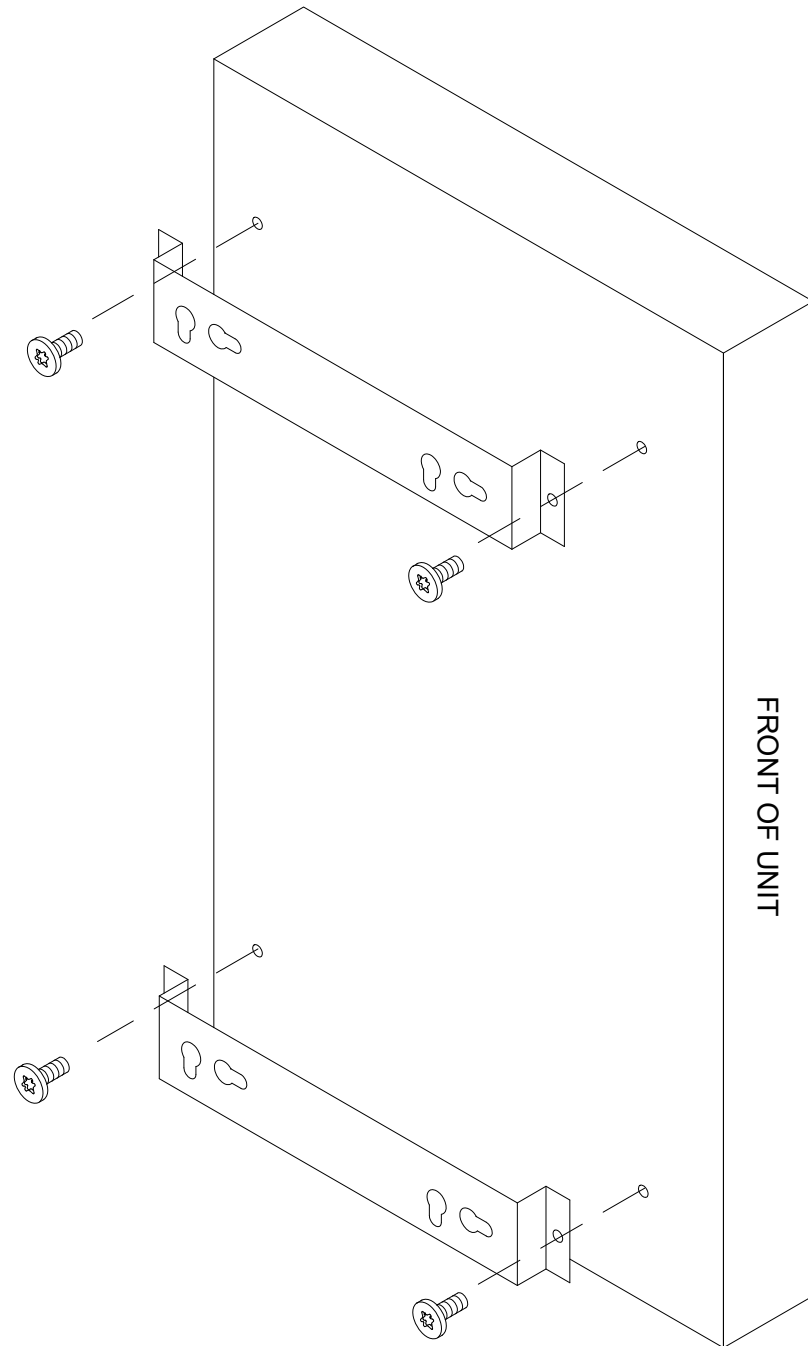

INSTRUCTIONS FOR FIXING TO THE WALL

DRILLING TEMPLATE

USE NO.8 ROUND HEAD SCREWS

UNIT MAY BE MOUNTED VERTICALLY
OR HORIZONTALLY

INSTRUCTIONS FOR FITTING THE WALL MOUNT BRACKETS

FIT BRACKETS TO UNIT USING SCREWS SUPPLIED
(4 off M3 x 6 Pan TORX)
TORX T10 DRIVER IS REQUIRED

IMPORTANT

USE 4 WALL FASTENERS, EACH CAPABLE OF SUPPORTING
6.75kg / 14lb 14oz, TO PROVIDE A SAFETY FACTOR OF 4.
USE APPROPRIATE FIXINGS, PLUGS OR ANCHORS, FOR THE
TYPE OF WALL THE UNIT IS TO BE MOUNTED ON.

Chck'd CD	App'd MJP	Date: 01/12/21	20132 Issue 1	UP4A701
-----------	-----------	----------------	---------------	---------