

AMPETRONIC

**HLS-1A
Hearing Loop Driver
Installation Handbook**

www.ampetronic.com

Handbook Contents

- Safety
- Installation & Connection
- Specification
- Warranty Information
- Declaration of conformity

Box Contents

- 1 x HLS-1A
- 1 x O-Ring
- 2 x Lid screw (M3x8)
- 1 x Wago Terminal Tool
- 1 x Handbook (this document)





This symbol is used to alert the user to important operating or maintenance instructions.



The Lightning bolt triangle is used to alert the user to the risk of electric shock.

SAFETY

1. It is important to read these instructions, and to follow them.
2. Keep this instruction manual in an accessible place.
3. No user serviceable parts. Refer all servicing to qualified personnel.
4. Clean only with a dry cloth. Cleaning fluids may affect the equipment.
5.  Install in accordance with the manufacturer's instructions.
6. Do not install this equipment near any heat sources such as radiators, heating vents or other apparatus that produces heat.
7. Refer all servicing to qualified personnel. Servicing is required when the apparatus has been damaged in any way, such as a power supply cord or plug is damaged, liquid has been spilled or objects have fallen into the apparatus, the apparatus has been exposed to any rain or moisture, does not operate normally or has been dropped.
8.  **WARNING** – To reduce the risk of fire or electric shock, do not expose this apparatus to rain or moisture. The apparatus shall not be exposed to dripping or splashing and no objects filled with liquids, such as vases, shall be placed on the apparatus.



CAUTION
RISK OF ELECTRIC SHOCK
DO NOT OPEN

**TO PREVENT ELECTRIC SHOCK REFER
SERVICING TO QUALIFIED PERSONNEL**

Installation and Connection

1. The unit can be securely mounted using the 2 x M4 mounting holes.
2. Connect loop feed cable to the loop clamp connector (see diagram).
3. Connect the low impedance speaker cable to input 1.
4. Use a screened cable <1m to connect an electret microphone to input 2.
5. Observing correct polarity, connect the DC power supply and apply power (see diagram). The power indicator will illuminate.
6. With the input signal on, increase the Input control until the green AGC LED illuminates with a normal signal.
7. Adjust the Output control until the amber Current LED is illuminated with signal peaks.
8. Use an Ampetronic FSM to test the system and adjust as required to be consistent with the requirements of the latest IEC 60118-4 Standard. Use the MLC control to adjust for high frequency loss.
9. Wind the cable through the restraint posts as shown in the image below.
10. Fit the O-ring to hold the cables in place.
11. Fit the lid using 2 screws, posting the cables through the mousehole.

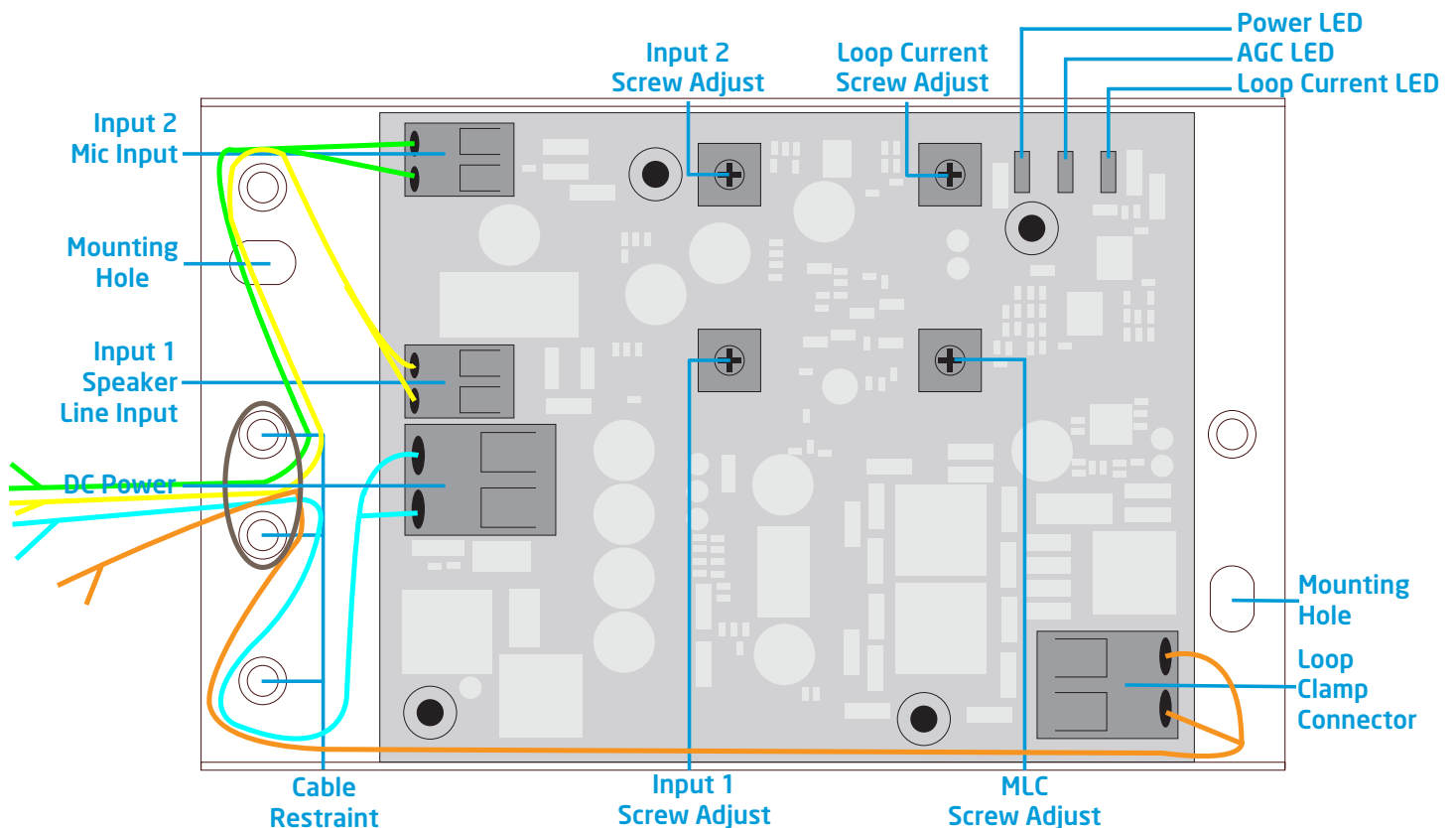

Fault Conditions

Overheating: The amplifier will output max rated sine current for 1 minute into rated load. After this period an internal protection mechanism will attenuate the output.

Overcurrent / Overvoltage: The amplifier will shutdown if its capabilities are exceeded for a short period. The amplifier will resume normal operation when operated within the normal parameters.

Technical Specifications According to IEC 62489-1:2014 Standard

PARAMETER	VALUE	
Max area coverage	45m ²	
Power supply range	12-24V DC	
Fuse	PTC resettable 1.5A	
Current consumption (12V DC)	Continuous pink noise	240mA DC
	Quiescent	50mA DC
	Short term peak	1200mA DC
Input 1 (Speaker Line level)	Rated source EMF (sensitivity)	-16dBu
	Overload	+22dBu
	Input Isolation	1500V
	Rated Source Impedance	1.8k Ω differential
Input 2 (Unbalanced Mic level)	Rated source EMF (sensitivity)	-55dBu
	Overload	-23dBu
	Electret Bias Voltage	12V through 11k Ω
	Rated Source Impedance	10k Ω
Current (into rated load)	Sine 1kHz	>3A _{RMS}
	Pink Noise	>1.5A _{RMS}
Frequency response (0.6A _{RMS})	100Hz to 5kHz \pm 1.5dB	
Compliance voltage	4.2V _{RMS}	
Weight	243g	
Dimensions	124 x 77 x 16mm	
Connectors	Clamp Terminals	
Environmental	IP20, -30°C to +75°C, <90% relative humidity	
Typical heat dissipation	<3W	

WARRANTY

This product carries a five year parts and labour warranty from date of shipment from Ampetronic. To qualify for the five year warranty, the product must be registered at www.ampetronic.com (products/warranty), without which the warranty will be valid for two years only.

The warranty could be invalidated if the instructions in this handbook are not followed correctly, or if the unit is misused in any way.

DECLARATION OF CONFORMITY

Manufacturer: Ampetronic Ltd.
Unit 2, Trentside Business Village, Farndon Road, Newark, Nottinghamshire,
NG24 4XB, United Kingdom.

Declares that the product: Conforms to the following EU Directive(s) and UK Statutory Instrument(s):

EMC: 2014/30/EU and 2016 No.1091

EN 55032:2015 Emissions,

EN 55035:2017 Immunity

Electrical Safety: 2014/35/EU and 2016 No.1101

EN 62368-1:2020

RoHS: 2011/65/EU and 2012 No.3032

REACH: 2006/1907/EC and 2020 No.1577

Date: March 2022

J.R. Pieters

Managing Director, Ampetronic Ltd.