

# HLS02-48 HANDBOOK

## Handbook Contents

- Safety
- Introduction
- Quick Start
- Overview
- Installation
- Troubleshooting
- Accessories
- Technical Specification
- Warranty
- Declaration Of Conformity

## Box Contents

- 1 x HLS02-48V or 48L
- 1 x Installation Commission Handbook





**This symbol is used to alert the user to important operating or maintenance instructions.**



**The Lightning bolt triangle is used to alert the user to the risk of electric shock.**

## SAFETY

1. It is important to read these instructions, and to follow them.
2. Keep this instruction manual in an accessible place.
3. Do not install this equipment near any heat sources such as radiators, heating vents or other apparatus that produces heat.
4.  This unit must be connected to a floating, isolated low voltage supply.
5. If using the 100V line input beware that hazardous voltages may be present on the 100V line.
6. Refer all servicing and installation to qualified personnel.
7. The amplifier generates some heat during normal operation. It should not be fitted without provision for adequate heat dissipation.
8. The HLS02-48 is designed to be incorporated in another enclosure which will provide environmental protection against liquid drips or spray.
9.  Disconnect / isolate power supply before changing any connections to the unit. Installation should be carried out in accordance with all applicable installation rules. A readily accessible disconnect device shall be incorporated in the installation power supply.

## INTRODUCTION

The HLS02-48 has been designed as a high quality stand alone induction loop driver suitable for use with localised systems in transport environments, car parks, help points, intercoms, speech security barriers, information points & interactive exhibits. It is intended to be installed inside a suitable enclosure.

The HLS02-48V has two inputs that allow connection to a 100V line PA system and a low level line / low Z speaker input. A monitor connection indicates unit status. HLS02-48L version has two low level inputs. A 15VDC version (the HLS02-15) is also available.

Connections are via detachable screw terminals which are quick and easy to connect. The HLS02-48 will cover an area up to 30m<sup>2</sup> depending on the application.

The HLS02-48 can be supplied with an output ratio transformer which may be used in specialised design applications. Contact Ampetronic for details and advice.

## GETTING IT ALL TO WORK - THE BASICS

The HLS02-48 is very easy to use. All you need is a power source, a signal source and a loop.

(Consult Ampetronic for loop design details)

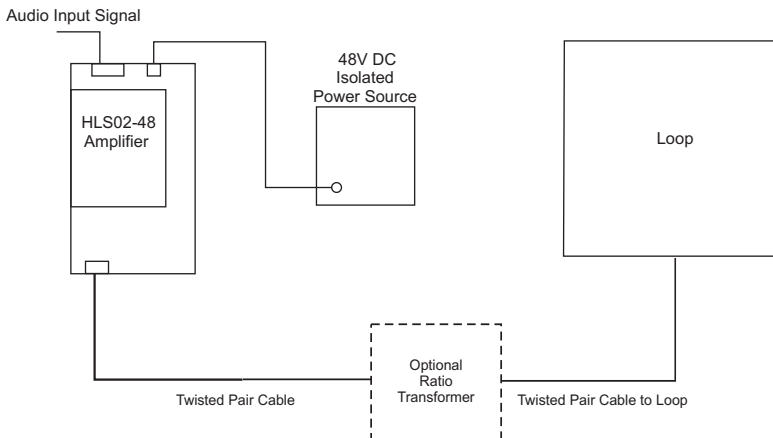

## QUICK START

For those who have a good appreciation of loop systems, the following is a very quick guide to setting up the amplifier:

## INSTALLATION

1. Turn all controls fully anti-clockwise.
2. Connect loop cable (with ratio transformer if used)
3. Connect signal input(s).
4. Connect power. See point 4 in Safety Section.

## OPERATION

5. Switch on - Check green "Power" LED illuminates to show power OK.
6. With the input signal on, increase the "INPUT" control until the green "Compression" LED begins to light with a normal signal.
7. Adjust the "DRIVE" control until the amber "Loop Current" LED lights at peaks in the input signal but not continuously NOTE: Once the "DRIVE" control is set, do not re-adjust it.
8. Repeat step 6. For the other input if used.
9. Listen to the output using a loop receiving monitor (e.g Ampetronic ILR3) and adjust the "TONE" control for best sound quality.

## OVERVIEW

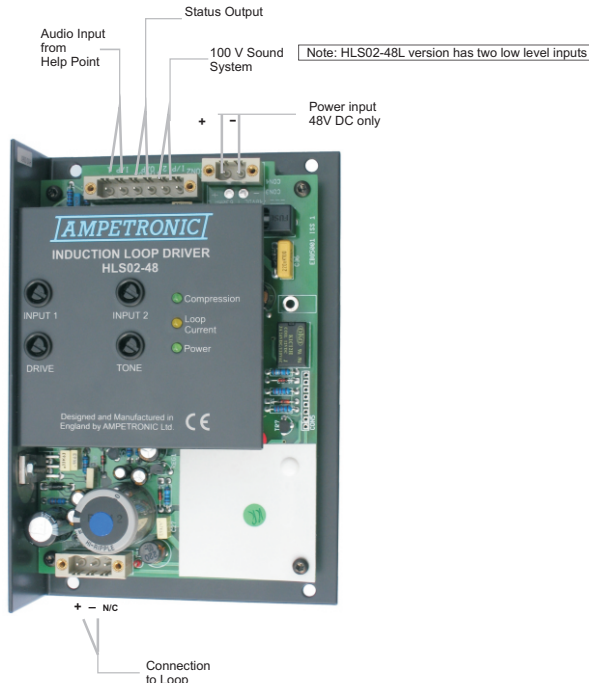

# HLSO2-48 Block Diagram

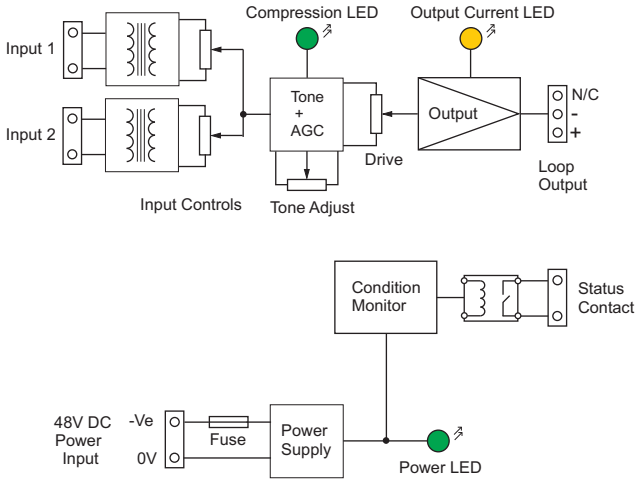

# Mounting Details

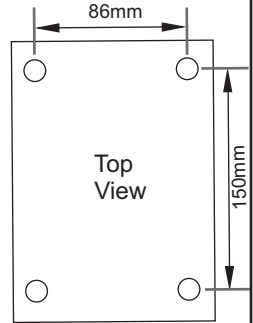

# I/O Connections

Input 2	
HLSO2-48V	100V speaker line
HLSO2-48L	Low Z speaker

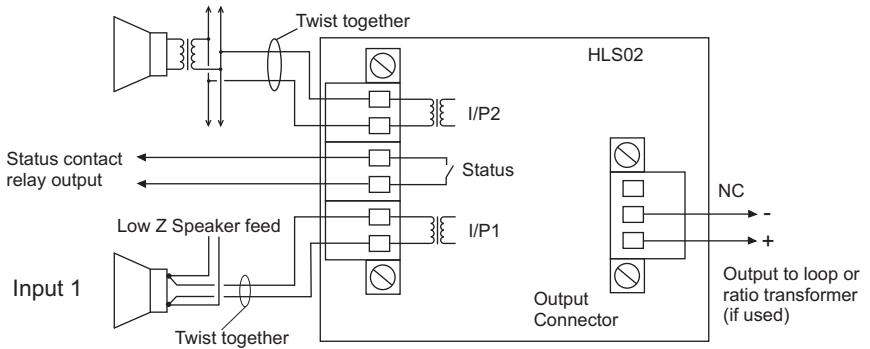

## INSTALLATION

### Location

The amplifier is designed to be mounted in another enclosure which will provide environmental protection against liquid drips or sprays. Mount the unit on a metal base plate or with ventilation, as the amplifier will get warm during normal operation.

### Tools

You will need small electrical hand tools including a wire stripper and a small flat bladed screwdriver.

### Connection & Set-Up

The HLS02-48 is normally supplied as a 48V DC input. Make sure you have the right voltage power supply before switching on.

1. Turn all controls fully anti-clockwise.
2. Connect the loop cable as shown in the I/O Connections drawing.  
Where using a perimeter loop (floor/ ceiling level), the feed cable should be tightly twisted and less than 20m in length. Total resistance of loop and feed must be between 0.3 and 1.0 (at DC). The correct design & positioning of the actual loop is vital for satisfactory system performance. If in doubt consult Ampetronic for advice about the loop configuration.
3. Connect the inputs appropriately:
  - a) 100V speaker line to Input 2. (HLS02-48L: Input 2 is low level speaker)
  - b) Low-level speaker (e.g intercom) or other low level signal to Input 1.You may use either or both inputs.



Do not route the input and output cables together.

4. Connect power supply to the HLS02-48. See point 4 in the “Safety” section.  
Ensure that the polarity is correct.
5. Switch on and check that the “Power” LED illuminates.
6. Select one input with a signal applied to that input, turn up the associated “INPUT” control until the green “Compression” LED is just illuminated.
7. Turn the “DRIVE” control clockwise until the “Loop Current” LED lights at peaks of the input signal. Once set, there is no need to adjust the “DRIVE” control again.
8. Repeat item 7 for the other input if used. When adjusting each input, make sure that the signal(s) are removed from the other inputs. This ensures that all signals are set to equivalent loudness and drive the compressor properly.
9. Monitor the output using an induction loop tester or headphone receiver (such as the ILR3) for adequate volume. Adjust the “TONE” control for best sound quality.
10. Connect the Status contact to an external signaling / monitoring system if required. Do not exceed the switching capacity.

## **TROUBLESHOOTING**

### **No Power:**

Check fuse and replace with correct rating if blown. Check correct orientation of DC power supply cables, and that supply voltage is correct.

### **No compression:**

Check input connections.

Check that there is sufficient signal level for the required input; i.e. HLS02-48V Input 2 100V Line level, 11V (23dBu) minimum signal is required. Low level speaker levels will be insufficient to drive I/P2, use other input or HLS02-48L.

Check that for intercom or similar low level inputs the drive level is sufficient; i.e. >78mV (-20dBu).

### **No Drive current:**

Check loop output connections: check that one wire is connected to the + output and the other wire to - output.

Check loop cable for open circuit.

Check that the output transformer is connected correctly (if fitted).

### **No Status:**

Check for correct supply voltage.

## Accessories

Output transformer or Loop Ratio Adapter (LRA11).

*Allows connection to specialised high current loops e.g. as used in help points.*

*N.B Contact Ampetronic technical dept. in order to discuss your requirements.*

## TECHNICAL SPECIFICATIONS

### Power Supply (DC):

Nominal Supply Voltage: 48V DC

Fuse: T 630 mA L

Range: 36V - 60V DC

### Power Consumption(48V DC):

Nominal Supply Voltage: 9W 180mA

Quiescent: 35mA

Peak Current: 360mA

(2.1A rms Audio Output)

### Inputs:

(Both transformer isolated floating input)

### Input 1 (Low-Z speaker):

Input Impedance: 5k

Sensitivity: -20dBu (78mV<sub>rms</sub>) for full output

Overload: >+19dBu (6.8V<sub>rms</sub>)

### HLS02-48L: Input 2 is same as Input 1

### Input 2 (100v Line PA):

Input Impedance: 136k

Sensitivity: 23dBu (11V<sub>rms</sub>) for full output

Overload: >+48dBu (190V<sub>rms</sub>)

1500V Isolation

### Compression (AGC):

40dB dynamic range

Compression controlled by adjusting input level

### Loop Design:

Depends on application.

See Application notes or consult

Ampetronic

### Outputs:

Current: >3A peak into 1

Voltage: >4.5V peak

Loop Resistance: 0.3 to 1 resistive or

1.5 max impedance reactive @ 1.6kHz

Connection: Screw terminal

Status: Isolated contact (>150V isolation), closed when amplifier functional.

Contact rating 1.25A @ 24Vdc,

0.4A @ 125Vac

Silver alloy contacts.

### Frequency Response:

80Hz - 5kHz  $\pm$  1.5dB at low level measured as loop current with no metal loss correction.

### Tone (Metal Loss Correction):

0 dB to 4dB / Octave boost.

Fully anticlockwise - flat response.

### Environmental:

Ambient temperature: -30°C to + 75°C

IP rating: IP10

### Physical:

Weight: 333g

Length: 160mm

Width: 107mm

Height: 45mm

### Standards:

Meets Relevant CE, EMC and safety standards.

*Please contact Ampetronic if you need further assistance.*

## **WARRANTY**

This product carries a five year parts and labour warranty from date of shipment from Ampetronic. To qualify for the five year warranty, the product must be registered at [www.ampetronic.com](http://www.ampetronic.com) (products/warranty), without which the warranty will be valid for two years only.

The warranty could be invalidated if the instructions in this handbook are not followed correctly, or if the unit is misused in any way..

## **DECLARATION OF CONFORMITY**

Manufacturer:                   Ampetronic Ltd.,  
Northern Road,  
Newark,  
Nottinghamshire.  
NG24 2ET  
United Kingdom.

Declares that the product:

Description:     Induction Loop Driver  
Type name:       HLS02-48V & HLS02-48L

Conforms to the following Directive(s) and Norm(s):

Directive 2004/108/EC  
EMC:             EN55103-1 : 2009 Emission  
                  EN55103-2 : 2009 Immunity

Directive 2006/95/EC  
Safety:          EN60065 : 2002

Date: January 2011  
J.R. Pieters  
Managing Director  
Ampetronic Ltd.